

**MANTA RAY<sup>®</sup> ENGINEERED  
EARTH ANCHOR SYSTEMS**

 MPS Civil Products Group

6430 East 49th Drive  
Commerce City, Co 80022 (USA)  
1-800-325-5360  
TEL: 303-286-8955  
FAX: 303-287-3866  
[www.earthanchor.com](http://www.earthanchor.com)  
[Sales@earthanchor.com](mailto:Sales@earthanchor.com)

# INSTALLATION GUIDELINES

- > **Introduction**
- > **How it works**
- > **Driving the Anchor with Handheld Breakers**
  - > **Equipment Required**
  - > **Driving with Drive Steel**
  - > **Drive Steel Removal**
- > **Mechanized Anchor Driving**
  - > **Mounted Breakers**
  - > **Vibratory Plate Compactors/Pile Drivers**
  - > **Rock Drills**
- > **Load Locking the Anchor**
- > **Clearance and Pilot Holes**
  - > **Clearance Hole Diameters and Hard Soil Pilot**
  - > **Installation in Decomposing Weathered or Marginally Competent Rock**
- > **Spec Sheets**

# INTRODUCTION >>>

MANTA RAY® and STINGRAY® earth anchors are driven tipping plate soil anchors for reaction of tensile loads. MANTA RAY Anchors have working capacities up to 13.5 tons, and STINGRAY Anchors have working capacities up to 40 tons. After driving the anchor to the required depth, the driving tool (called drive steel) is removed. The anchor is then tipped and proof tested with the Load Locker from its edgewise-driving position to present its bearing area to the soil. This is called “load locking”, and provides an immediate proof test of each anchor.

# How It Works >>>



Drive Anchor



Remove Drive Steel



Pull On Rod



Load Tested

# DRIVING MANTA RAYS WITH HANDHELD BREAKERS >>>

## EQUIPMENT REQUIRED

**Air/Hydraulic Hammers:** We recommend a minimum 90 pound hydraulic or pneumatic hammer.

**Gasoline Or Electric Hammers:** May be used successfully for the smallest anchors in soft soils, for shallow depths, but are not recommended for MR-4 or larger anchors.

## DRIVING THE ANCHOR WITH MANTA RAY SG DRIVE STEEL

**CAUTION:** All subsurface structure location precautions must be observed prior to installation. Construction personnel must observe safety precautions regarding attire, including hard hats, gloves, safety glasses, ear protectors, etc.

MANTA RAY SG drive steel was designed for flexibility by allowing all components to mate with each other. Drive steel components are: (Refer to drawing #51432-ODA)

**Radius Drive Tip:** This piece is shaped to fit into the anchor on one end and threaded on the other.

**Shank:** This piece is sized to fit the hammer chuck on one end and is threaded on the other.

**Extension:** This piece is threaded on both ends.

**Coupler:** This piece is internally threaded to join shanks, radius tips and extensions together.

The drive steel utilizes a left-handed thread. Make sure that the steel is fully threaded into the coupler, and that the coupler can “free float” once the steel is coupled together. Check this “free float” by moving the coupler back and fourth on the drive steel. It should move freely 3/4 in before stopping.

1. Connect shank and radius drive tip together with a coupler.
2. Thread the anchor rod into the shackle on the anchor using a wrench to tighten. If using an “All-Thread” anchor rod, make sure the rod does not thread through the shackle which can cause the rod to bind on the anchor eye. Binding will prevent the proper rotation of the anchor during Load Locking. Vibration during driving causes anchor rods to loosen. Do not allow the anchor rod to completely un-thread from the anchor. This situation can be worse when multiple lengths of rods are coupled together.
3. Insert the radius tip into the back of the anchor.
4. Insert the shank into the hammer chuck and raise the jack hammer until the proper installation angle is reached. Begin driving the anchor into the ground at the required angle. Cease driving when the drive steel has penetrated the ground to the middle of the first drive steel coupler.

**CAUTION: On long drives, in very hard soils, the couplers may become hot. Wear gloves.**

5. Remove the hammer from the shank, (be careful not to remove the drive steel from the anchor) remove the shank from the coupler and place a drive steel extension and another coupler between the original drive tip and the shank. Replace the hammer on the shank and continue driving the anchor until the second coupler is at ground level.
6. Repeat the drive steel addition process, and continue driving until the top of the anchor rod is level with the ground in very hard soil, or is countersunk approximately 8-10 inches in medium to soft soil. When countersinking, screw the adapter setting bar (ASB) to the anchor rod PRIOR to driving the anchor rod below the ground level. The adapter setting bar extends the anchor rod through the Load Locker.
7. The above operation takes approximately 6-8 minutes for an 8 foot depth in medium to soft soils, and longer in proportion to the hardness of the soil, up to a maximum of 15-20 minutes in extremely hard soils.
8. NOTE: If the anchor strikes an object and makes no further movement for five minutes, an object is probably in its path; either a rock, layer of rock, or

other solid objects, and the anchor may not penetrate to the depth desired. At this stage the anchor can still be removed, as long as the drive steel is not removed from the anchor. The Load Locker can be used to remove the anchor by pulling on the anchor rod, again only if the drive steel is not removed, as the anchor will begin to rotate into its locked position otherwise. The operator then can reuse the anchor in a slightly different location to achieve installation.

## **DRIVE STEEL REMOVAL**

1. In most cases the drive steel is simply removed by an upward pull on the hammer. If the drive steel does not break free from the anchor immediately, pulling up on the hammer while operating the hammer will vibrate the drive steel out of the hole.
2. Remove the hammer from the shank and pull the drive steel out of the ground.

**CAUTION: Gloves must be worn, as the drive steel sections and particularly the couplers may become very hot while the anchor is being driven.**

3. There are very rare occurrences when the drive steel will not manually break free. This can happen in dry, rocky soil when rocks fall into the hole made by driving the anchor and lodge against the drive steel. This can also happen in very soft, wet (muddy) soil when the soft soil collapses around the drive steel during driving. The drive steel can also become stuck when anchors “steer” around small obstacles such as imbedded rocks. This “steering” can cause the drive steel to bow slightly which will bind it in the ground.

An “Extractor Bar” (SG-X) is included with each drive steel set, or may be purchased separately. If the drive steel does not manually break free, simply remove the hammer from the shank and screw the extractor bar (it also is rope threaded) into the coupler. Use the Load Locker to pull up on the “extractor bar” to break the drive steel free. Be careful as the drive steel is pulled out and removed to not allow portions of the drive steel to fall back down the hole. Usually there is some obstruction to removing the drive steel, and once they are broken free with the Load Locker they can easily be removed by hand.



to bend and break MANTA RAY drive steel and couplers if proper alignment is not maintained. It is advisable to use only as much power as is required to drive the anchors at a reasonable speed. This requires some experimentation with the combination of “throttle position” (i.e., tool flow rate) and boom crowd force.

A Socket Adapter for the drive steel is available for use with mounted breakers. (See drawing #10019-ODA) A blunt tool in the hammer is required. The Socket Adapter threads onto the top of the drive steel, providing a female socket for the blunt tool. After driving, the drive steel is removed using a chain or sling between the Socket Adapter and the boom.

### VIBRATORY PLATE COMPACTORS/PILE DRIVERS

See drawing #10020-ODA

Vibratory plate compactors have been very successful driving MANTA RAY Anchors. Depending upon the application, some minor modifications to the plate may be required. Attachment of a “retention cup” to the bottom of the plate to retain the MANTA RAY drive steel is required. Steel tubing or pipe of 2 ¼” ID (just large enough to slip over the MANTA RAY drive steel Cap Adapter) can be welded to the bottom of the plate.

A hook for attachment of a cable or chain to remove the drive steel after driving is also required.

Vibratory plate compactors in the range of 4,000 to 16,000 lbs of centrifugal vibratory force are best suited to MANTA RAY Anchor driving.

In general, vibratory methods work best in granular (sandy) soils, and not as well in cohesive (sticky, hard clay) soils.

**CAUTION:** Some vibratory plate compactors have the capacity to bend and break MANTA RAY drive steel and couplers if proper alignment is not maintained. It is advisable to use only as much power as is required to drive the anchors at a reasonable speed. This requires some experimentation with the combination of “throttle position” (i.e., tool flow rate) and boom crowd force.

### CRAWLER DRILLS, ROCK DRILLS, TRACK DRILLS, ETC.

These machines are very powerful and can install anchors very quickly. Both pneumatic and hydraulic versions are available. They are typically used when large quantities of

## MECHANIZED ANCHOR DRIVING >>>

### MOUNTED BREAKERS

See drawings: #10019-ODA - Backhoe #51247-ODA - Skid steer

Mounted breakers up to 500 ft-lbs impact class may be used to install MANTA RAY Anchors. Please note that MANTA RAY Anchors are designed to be driven in a straight line. This will require a skilled operator and some movement of the carrier vehicle to maintain proper alignment during driving.

**CAUTION:** Boom mounted breakers have the capacity

anchors are placed on one job where equipment access is not a concern.

Rock drills that have independent rotation are best suited to MANTA RAY driving. Depending upon the details of the drill steel some modification may be required. In order to properly fit the MANTA RAY Anchor the first piece of steel must fit completely into the base of the socket in the MANTA RAY and spin freely. The tip must be fully rounded and reasonably smooth. For lathe turning, the dimensions should be 1.245" +/- .015" diameter and 8.5" + .250" - 0.00" long. This can be achieved by lathe turning or grinding an existing extension, but it is best if a custom radius tip piece and adapter coupler from us is used.

Grinding or turning an existing piece of drill steel causes stress concentrations and disturbs the heat-treated surface of the steel. This usually results in premature failure of the drill steel.

Please consult with us for your particular requirements.

When using a rock drill to drive MANTA RAY Anchors the drill steel is allowed to rotate in the socket in the anchor and usually causes no harm, but rather serves to help keep the drill steel couplers tight. The socket in the anchor should be greased to avoid excess friction and galling.

## LOAD LOCKING THE ANCHOR >>>

See drawing #E0110

The anchor must be proof tested (using the Load Locker) to the desired holding capacity.

The Load Locker consists of a base plate, hollow cylinder jack, hydraulic control valve, a gauge, adapter setting bar, and tapered jaws to grab the adapter setting bar (ASB). For some applications, such as retaining walls, a custom or modified base plate may be necessary. Please consult with us if you have any questions. The Load Locker requires hydraulic power supply with these characteristics: 2000 PSI maximum pressure, 2-8 GPM, open center. Many installers power the Load Locker from the auxiliary circuit of a skid steer or backhoe.

**CAUTION: Many auxiliary circuits on construction equipment can far exceed the 8 GPM limit of the Load Locker. In this case, a Flow Control Device is required.**

We offer a separate small portable gasoline powered hydraulic unit (GPU-2). Several other portable units are available from other manufacturers as well and the Load Locker may be adapted with proper couplers to these units.

**CAUTION: The Load Locker is capable of pulling with forces up to 25,000 lbs. The following precautions must be taken:**

- **Operators must wear proper safety attire including but not limited to; steel-toe work shoes, gloves, hard hats, and safety glasses.**
- **Ensure full engagement of all threaded connections.**
- **DO NOT stand directly in line with the adapter setting bar or anchor rod during Load Locking. Stand off to the side.**
- **Be sure to set the by-pass pressure on the Load Locker to ensure that the maximum load produced by the Load Locker does not exceed the structural rating of the anchor.**
- **Refer to the Specifications Chart for the structural ratings.**
- **Refer to instructions to set the by-pass pressure on the Load Locker**

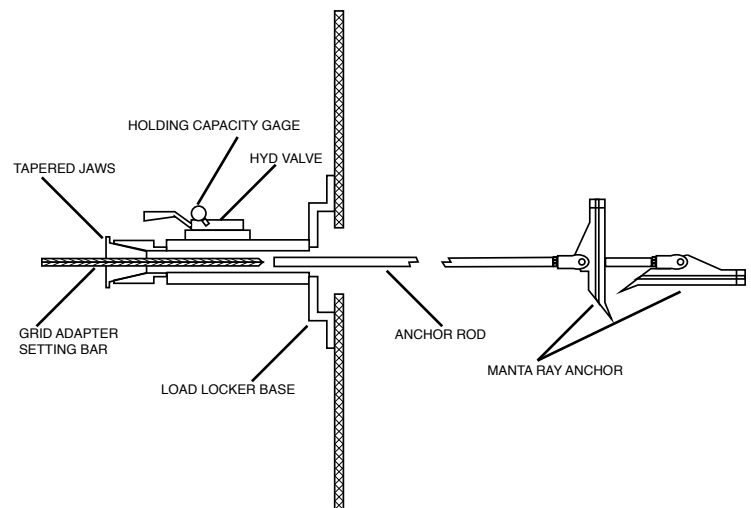



1. Screw the adapter setting bar onto the top of the anchor rod, which is now at ground level or countersunk. Place the base plate over the top of the anchor rod and adapter setting bar. Also, in softer soils the base plate can be set on top of 4" x 4" timbers for increased surface area so that any sinking tendency will be eliminated.

2. Place the hydraulic jack over the adapter setting bar and onto the base plate. The tapered jaws are placed over the ASB when the jack is fully retracted. The load locker is now ready to lock the anchor.

3. With the hydraulic circuit deactivated, attach the hydraulic hoses from the power source to the hoses on the control valve mounted on the jack.

4. After activating the hydraulic circuit the operator shifts the valve and the jack extends pulling the anchor back and rotating the anchor into the locked position by watching the gauge on the Load Locker, the operator can determine the holding capacity at any time during the Load Locker cycle. Up to three to four cycles could be required to set the anchor depending upon anchor size and soil conditions. Each time the jack is retracted the jaws must be re-set. After locking the anchor proceed with testing the anchor in accordance with project specifications. NOTE: This is usually done with the Load Locker, so no separate set up is required. This proof test is usually done by maintaining a constant load while monitoring the movement of the anchor. (See drawing #E0110) By virtue of the design of the control valve on the load locker it will not maintain a constant load when released into the neutral position. To maintain a load, the operator must "feather" the control valve and monitor the pressure reading on the gauge or set the bypass valve on the Load Locker. For more details request a copy of the Load Locker manual.

5. After the Load Locker is removed, the appropriate thimble or plate is attached to the anchor rod and installation is complete, with an anchor that has been proof tested to the desired capacity.

6. The MANTA RAY Load Locker is a custom designed hydraulic jack designed to read the force applied to the anchor directly in lbs or kN on the gauge.

For critical applications, the Load Locker should be calibrated by a test lab using the same gauge and power supply that will be used for the job. This calibration should be performed prior to the start of the job, and any time a gauge is changed. We can provide load verification

services or calibration instructions for independent test labs.

7. Other Load Locking methods: Any hollow hydraulic jack and power unit may be used to lock MANTA RAY Anchors. Common manufacturers are ENERPAC and SPX.

**CAUTION: Many of these jacks are capable of developing very high loads in excess of the structural rating of MANTA RAY Anchors.**

Most of these systems have very slow flow rates and therefore take longer to tip the MANTA RAY Earth Anchors. It is generally accepted that a relatively fast initial pull helps initiate the tipping motion and achieves full deployment and maximum load with the least pull-back of the anchor rod.

8. Other Power Units for the LL-1 Load Locker: SPX, ENERPAC, or other power units (gasoline, pneumatic, electric) can be used to provide hydraulic power for the LL-1 Load Locker. Because of the low flow rates produced by many of these power units Load Locking anchors will usually take longer than with typical hydraulic tool power units. The Load Locker bypass valve will need to be adjusted to achieve the required pressure.

The ideal power source for the LL-1 Load Locker should provide: 5-8 gallons per minute 2000 PSI maximum pressure.

**CAUTION: If a high pressure/low flow rate power unit is used, the hydraulic by-pass valve on the Load Locker must be re-adjusted to limit the maximum pressure to 2000 PSI or a maximum force of 25,000 lbs, or lower depending upon the maximum allowable load for the particular anchor assembly.**

9. TO ADJUST THE BY-PASS PRESSURE:

- Place the jack on the floor, bench, or ground without the base or tapered jaws.
- Connect the jack to the same hydraulic power source that will be used in the field for Load Locking anchors.
- Start the hydraulic power source and make sure it is running properly.
- Extend the jack to the top of its stroke. Keep the control valve shifted to the extension position. The by-pass valve will now be limiting the hydraulic pressure. You can usually hear an audible "screeching" noise when the by-pass valve is operating. Read this pressure

directly on the pressure gauge.

- If the by-pass pressure reading is not correct, follow the steps below to adjust it.
  - Loosen the lock nut.
  - Turn the Allen screw to adjust the by-pass pressure while the by-pass valve is operating, as in Step 4.
  - Tighten the lock nut.

We can supply alternative power units for the Load Locker, please consult for availability.

## ADDITIONAL INSTALLATION PROCEDURES >>>

There are extremely hard soils that are comprised of dense sand or very dense/dry compacted clay. Instead of taking up to 30 minutes to drive the MANTA RAY in these soils, the following are methods to speed up installations and fatigue in the drive steel, hammer, etc.:

**Pre-drilled Hole:** By using an earth auger and drilling a hole the proper depth, the MANTA RAY can be installed in the normal fashion down this hole.

We recommend a portable hydraulic earth drill to drill the pilot hole. A chart of pilot hole sizes is below.

### CLEARANCE HOLE DIAMETERS AND HARD SOIL PILOT HOLE DIAMETERS

#### MANTA RAY EARTH ANCHORS

Installation of MANTA RAY Anchors in hard soils can be greatly helped by the use of a pilot hole. Typically, the pilot hole has no significant effect on the holding power of the anchor. There are many acceptable methods of drilling pilot holes and many manufacturers of equipment to do so. Recommended hard soil pilot hole diameters and clearance hole diameters are charted below.

Model	Clearance Hole Diameter	Minimum Pilot Hole Diameter for Hard Soil
MR-68	1.75"	1.50"
MR-88	3.00"	2.75"
MR-4	4.00"	3.50"
MR-3	4.00"	3.50"
MR-2	4.50"	4.00"
MR-1	7.00"	4.00"
MR-SR	12.00"	4.00"

### INSTALLATION IN DECOMPOSING WEATHERED OR MARGINALLY COMPETENT ROCK

MANTA RAY Anchors can be installed in these conditions, but a pilot hole is required. Normally a top hammer rock drill or down the hole hammer is required to drill the pilot hole. The only anchors for these conditions are the smaller "wingless" anchors (MR-68, MR-88, MR-4, MR-3, MR-2) because they will pass down a circular hole, then tip and lock across the hole. These rock conditions typically require a larger pilot hole than hard soil. Due to the hardness and incompressibility, the anchors tend to slide up the smaller pilot hole. Since all conditions are different, some experimentation with pilot hole diameter may be necessary. A test anchor is always recommended. The following chart is a guideline based upon field experience and shows recommended anchor proof test loads and pilot hole sizes for these conditions. Pea gravel, drill cuttings, or virtually any other type of backfill has significantly helped the anchors tip and lock inside the rock.

Anchor Model	Max Proof Test Load	Pilot Hole Size
MR-68	3,000	3.00"
MR-88	6,750	3.50"
MR-4	12,600	4.50"
MR-3	14,500	5.00"
MR-2	27,000	5.00"

P/N: 51432-ODA

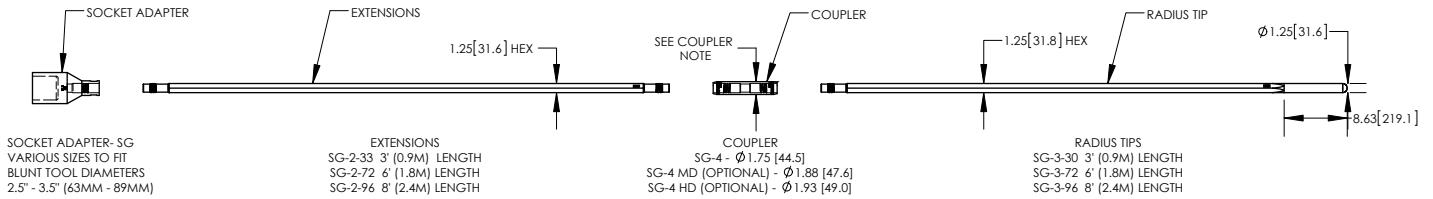

TO COUPLE:  
TURN DRIVE STEEL COUNTERCLOCKWISE AS VIEWED FROM ABOVE.

TO UN COUPLE:  
PULL BACKWARD AND ROTATE CLOCKWISE AS VIEWED FROM ABOVE.

NOTE 1) THIS SYSTEM SHOULD BE USED WITH BOOM MOUNTED DEMOLITION (PAVEMENT BREAKER) HAMMERS. A BLUNT TOOL IN THE IMPACT HAMMER IS REQUIRED. ANY FORM OF A POINT IS UNACCEPTABLE.

NOTE 2) MAXIMUM ALLOWABLE IMPACT ENERGY FOR THIS SYSTEM IS 350 FT-LBS (407J). FOR LARGER HAMMERS, THE SG150 DRIVE STEEL SYSTEM SHOULD BE USED

NOTE 3) 6' AND SHORTER DRIVE STEEL LENGTHS ARE CONSIDERED OPTIMUM FOR THIS SYSTEM. 8' LENGTHS REQUIRE EXTRA OPERATOR CARE TO MAINTAIN ALIGNMENT AND NOT TO USE EXCESSIVE CROWD FORCE.

THE SG150 DRIVE STEEL SYSTEM IS HEAVIER AND STIFFER AND IS RECOMMENDED FOR 8' LENGTHS.

NOTE 4) THE WRENCH FLATS ON THIS SYSTEM ARE DESIGNED FOR 24" (600MM) ADJUSTABLE WRENCHES.

NOTE 5) ALL MANTA RAY DRIVE STEEL UTILIZES LEFT HANDED STINGER THREADS. THIS PATENTED THREAD FORM REDUCES HEAT BUILD UP IN COUPLERS.

A	BF	06/11/13	
REV.	BY	DATE	
DIMENSIONS: INCHES [MM]			 MacLean Power Systems, LLC dba <b>FORESIGHT PRODUCTS</b> 6430 EAST 49TH DRIVE COMMERCE CITY, COLORADO 80022
<b>PROPRIETARY AND CONFIDENTIAL</b> THIS DOCUMENT AND THE INFORMATION IT CONTAINS IS THE SOLE PROPERTY OF MACLEAN POWER, LLC dba FORESIGHT PRODUCTS. IT IS NOT TO BE COPIED OR REPRODUCED IN WHOLE OR PART, NOR IS THE INFORMATION TO BE RELAYED TO ANY OTHER INDIVIDUAL COMPANY WITHOUT THE WRITTEN PERMISSION FROM MACLEAN POWER, LLC. dba FORESIGHT PRODUCTS. ACCEPTANCE OF THIS DOCUMENT CONSTITUTES AGREEMENT TO THESE RESTRICTIONS.			
TITLE:			MANTA RAY SG DRIVE STEEL FOR MOUNTED BREAKERS
PART NUMBER:			51432-ODA
SCALE: 1:20			REV. A
SHEET NUMBER: 1 OF 1			



**PROCEDURE**

IMPORTANT NOTE: THIS PROCEDURE WORKS BEST WITH A CREW OF TWO: ONE WORKER OPERATES THE BOBCAT AND THE OTHER WORKER STANDS BACK FROM THE BOBCAT TO SIGNAL THE REQUIRED ADJUSTMENTS TO THE OPERATOR TO MAINTAIN PROPER ALIGNMENT OF THE HAMMER AND DRIVE STEEL.

- STEP 1) HYDRAULIC HAMMER MUST HAVE A BLUNT TOOL! ANY FORM OF A POINT ON THE TOOL IS UNACCEPTABLE.
- STEP 2) ATTACH THREADED SOCKET ADAPTER ONTO RADIUS TIP DRIVE STEEL SECTION (LEFT HAND THREAD)
- STEP 3) PLACE RADIUS TIP INSIDE ANCHOR. POSITION ANCHOR AT INSERTION POINT.
- STEP 4) POSITION BREAKER OVER DRIVE STEEL, AND LIGHTLY "CROWD" THE HAMMER ONTO THE DRIVE STEEL.
- STEP 5) TURN AUXILIARY CIRCUIT "ON" AND BEGIN DRIVING ANCHOR. KEEP "CROWDING" THE ANCHOR JUST ENOUGH FOR THE HAMMER TO KEEP HITTING, BUT NOT ENOUGH TO BEND THE DRIVE STEEL.
- STEP 6) DRIVE STEEL EXTRACTION. IF DRIVE STEEL CANNOT BE REMOVED BY HAND, CONNECT A CHAIN BETWEEN THE BOBCAT AND THE SOCKET ADAPTER, AND PULL OUT USING THE BOBCAT.

**HORIZONTAL INSTALLATION USING SG SERIES DRIVE STEEL**

**P/N: 51247-ODA**

ADD COUPLERS: SG-4HD (SG-4MD, SG-4 OPTIONAL)  
 ADD EXTENSIONS: SG-3 3' (0.9M)  
 SG-3-72 6' (1.8M)  
 SG-3-96 8' (2.4M)  
 AS REQUIRED TO ACHIEVE REQUIRED ANCHOR PENETRATION

MOVE BOBCAT INWARD TO "CROWD" ADJUST HEIGHT OF ARMS AND BUCKET ANGLE TO MAINTAIN A STRAIGHT DRIVE AND TO ADJUST FOR TERRAIN VARIATIONS

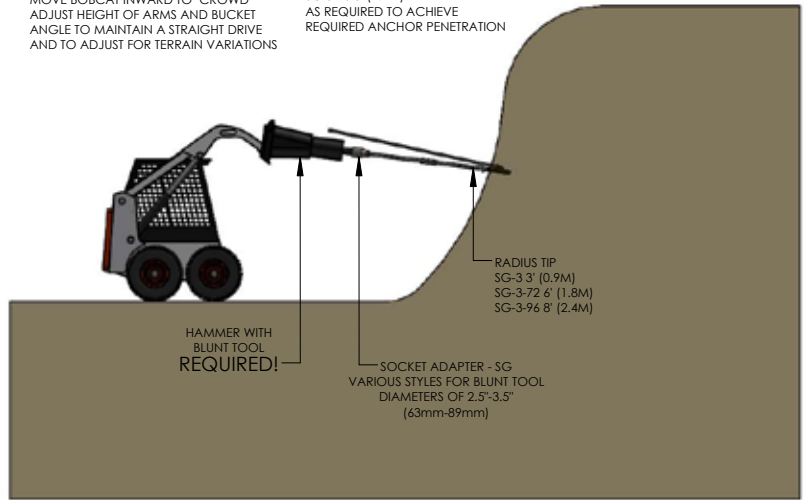

**OPTIONAL SG150 SERIES DRIVE STEEL SHOWN HERE**

SLOWLY LOWER BOBCAT "ARMS" TO APPLY SLIGHT DOWNWARD PRESSURE ("CROWD") AS ANCHOR IS DRIVEN

ADD COUPLERS: SG150-4  
 ADD EXTENSIONS: SG150-3 3' (0.9M)  
 SG150-3-72 6' (1.8M)  
 SG150-3-96 8' (2.4M)  
 AS REQUIRED TO ACHIEVE REQUIRED ANCHOR PENETRATION

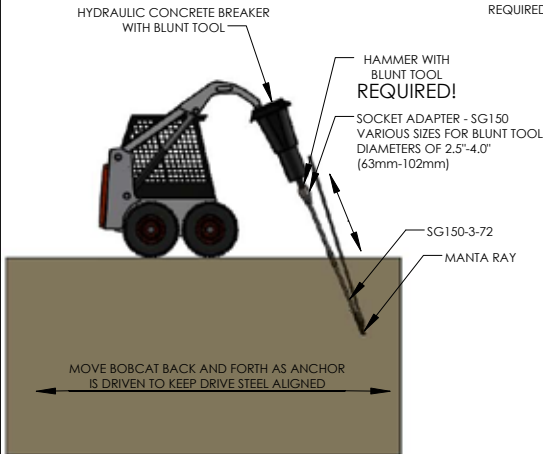

D	JD	06/17/09
REV.	BY	DATE

DIMENSIONS: INCHES [MM]

**PROPRIETARY AND CONFIDENTIAL**  
 THIS DOCUMENT AND THE INFORMATION IT CONTAINS IS THE SOLE PROPERTY OF MACLEAN POWER, LLC dba FORESIGHT PRODUCTS. IT IS NOT TO BE COPIED OR REPRODUCED IN WHOLE OR PART, NOR IS THE INFORMATION TO BE RELAYED TO ANY OTHER INDIVIDUAL COMPANY WITHOUT THE WRITTEN PERMISSION FROM MACLEAN POWER, LLC, dba FORESIGHT PRODUCTS. ACCEPTANCE OF THIS DOCUMENT CONSTITUTES AGREEMENT TO THESE RESTRICTIONS.

MacLean Power Systems, LLC dba  
**FORESIGHT PRODUCTS**  
 6430 EAST 49TH DRIVE  
 COMMERCE CITY, COLORADO 80022

TITLE:  
**MANTA RAY INSTALLATION WITH BOBCAT (SKID STEER)**

PART NUMBER: <b>51247-ODA</b>	REV. <b>D</b>
SCALE: 1:75	SHEET NUMBER: 1 OF 1

PAPER SIZE	CATALOG NUMBER
<b>A</b>	E0110

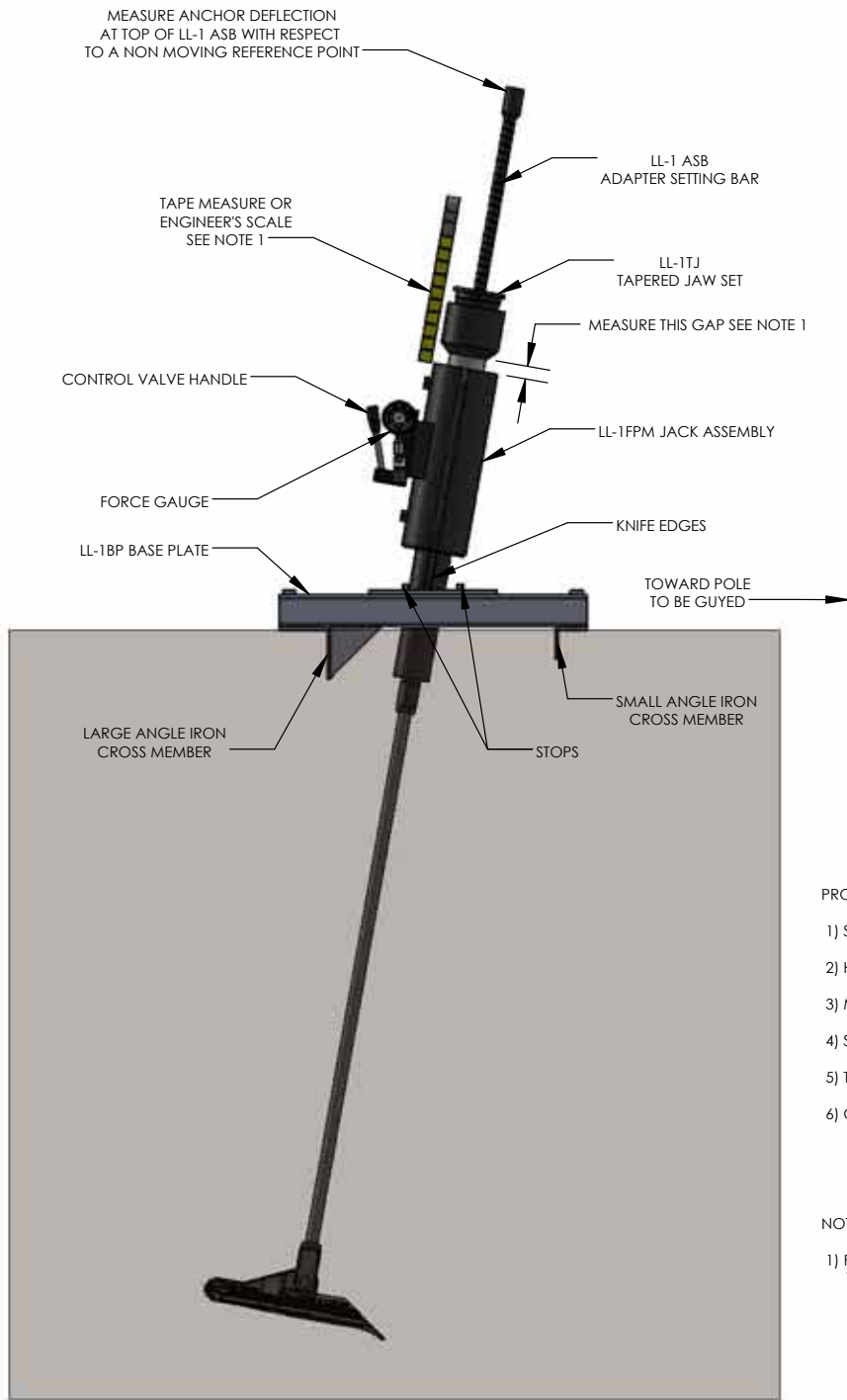

PROOF TEST PROCEDURE:

- 1) SET BYPASS VALVE TO DESIRED PROOF TEST VALUE
- 2) HOLD CONTROL VALVE COMPLETELY OPEN
- 3) MEASURE DEFLECTION AT BEGINNING AND END OF REQUIRED TIME
- 4) SUBTRACT BEGINNING DEFLECTION FROM ENDING DEFLECTION
- 5) THIS DIFFERENCE IS THE ANCHOR MOVEMENT
- 6) COMPARE TO ALLOWABLE MOVEMENT.

NOTES:

- 1) FOR NON-CRITICAL ANCHOR APPLICATIONS SOME INSTALLERS USE A TAPE MEASURE AND MONITOR THE MOTION OF THE CYLINDER TO INDICATE ANCHOR MOVEMENT. BE AWARE THAT SLIP BETWEEN THE LL-1ASB AND THE JAWS OR SINKING OF THE BASE CAN BE A FALSE INDICATOR OR ANCHOR MOVEMENT.

DRAWING NUMBER:		E0110	
SHEET NAME:		1 OF 1	
PRODUCT DESCRIPTION			
PROOF TESTING USING LL-1 ANCHOR LOCKING KIT			
DRAWN BY:		JD	DATE:
			07/05/13

This drawing contains confidential information that is the property of MacLean Power, L.L.C. ("MacLean"). Use of MacLean's confidential information without MacLean's express written consent is strictly prohibited and may expose you to legal liability. If you believe that you received this material in error, please destroy it or return it to "MacLean Power, L.L.C., 11411 Addison Street, Franklin Park, Illinois 60131, "USA."



**MACLEAN  
POWER  
SYSTEMS**

www.maclepower.com

NOTE: MAXIMUM ALLOWABLE IMPACT ENERGY FOR THIS SYSTEM IS 350 FT-LBS.  
FOR LARGER HAMMERS USE SG150 DRIVE STEEL

P/N: 10019-ODA

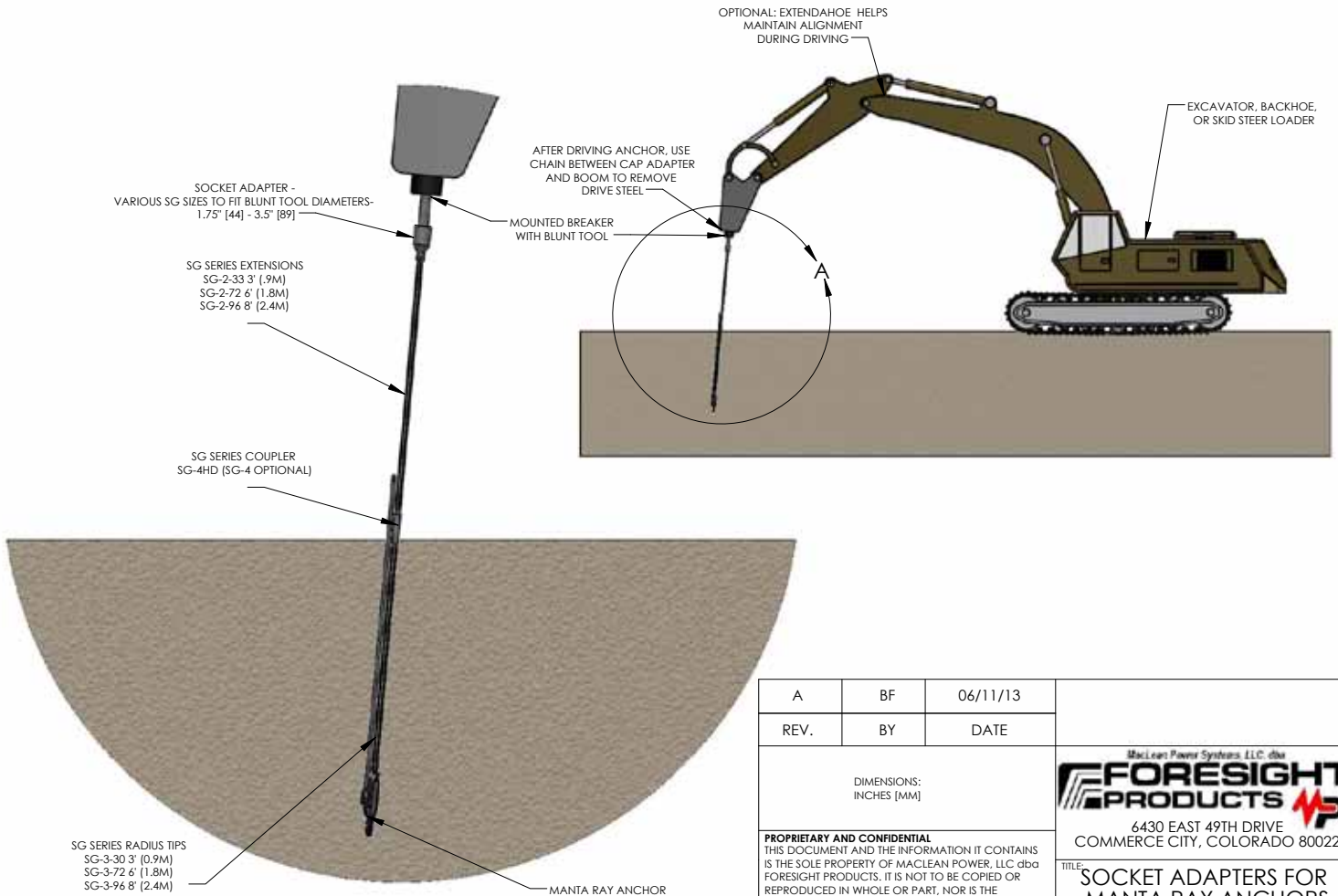

SG SERIES RADIUS TIPS  
SG-3-30 3' (0.9M)  
SG-3-72 6' (1.8M)  
SG-3-96 8' (2.4M)

SG SERIES COUPLER  
SG-4HD (SG-4 OPTIONAL)

SOCKET ADAPTER -  
VARIOUS SG SIZES TO FIT BLUNT TOOL DIAMETERS-  
1.75" [44] - 3.5" [89]

SG SERIES EXTENSIONS  
SG-2-33 3' (.9M)  
SG-2-72 6' (1.8M)  
SG-2-96 8' (2.4M)

DETAIL A  
SCALE 1 : 35

A	BF	06/11/13	 <p>MacLean Power Systems, LLC dba <b>FORESIGHT PRODUCTS</b> 6430 EAST 49TH DRIVE COMMERCE CITY, COLORADO 80022</p>
REV.	BY	DATE	
DIMENSIONS: INCHES [MM]			TITLE: <b>SOCKET ADAPTERS FOR MANTA RAY ANCHORS</b>
PROPRIETARY AND CONFIDENTIAL THIS DOCUMENT AND THE INFORMATION IT CONTAINS IS THE SOLE PROPERTY OF MACLEAN POWER, LLC dba FORESIGHT PRODUCTS. IT IS NOT TO BE COPIED OR REPRODUCED IN WHOLE OR PART, NOR IS THE INFORMATION TO BE RELAYED TO ANY OTHER INDIVIDUAL COMPANY WITHOUT THE WRITTEN PERMISSION FROM MACLEAN POWER, LLC, dba FORESIGHT PRODUCTS. ACCEPTANCE OF THIS DOCUMENT CONSTITUTES AGREEMENT TO THESE RESTRICTIONS.			
PART NUMBER:		10019-ODA	REV. A
SCALE: 1:28		SHEET NUMBER: 1 OF 1	

P/N: I0020-ODA

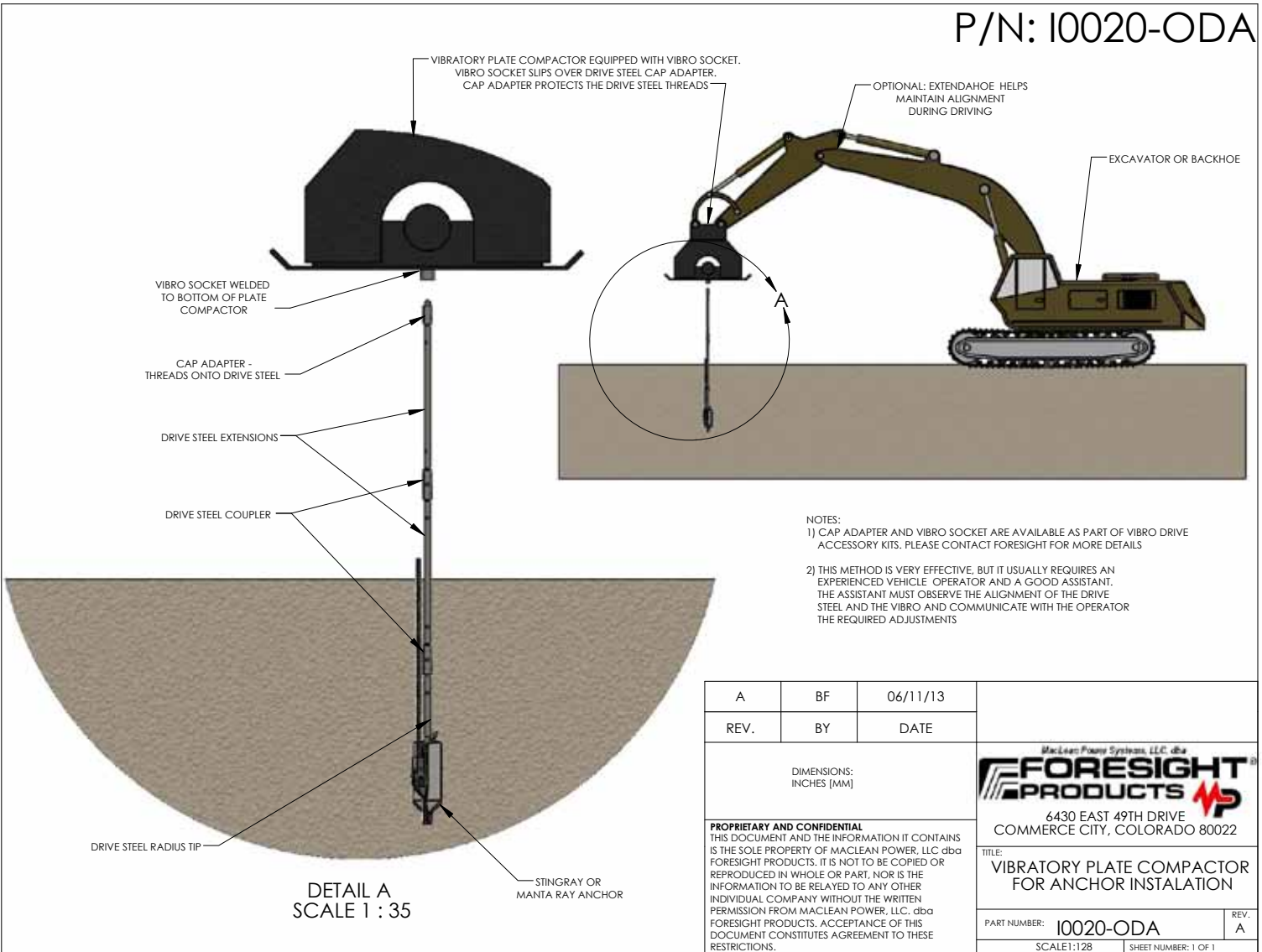

- NOTES:
- 1) CAP ADAPTER AND VIBRO SOCKET ARE AVAILABLE AS PART OF VIBRO DRIVE ACCESSORY KITS. PLEASE CONTACT FORESIGHT FOR MORE DETAILS
  - 2) THIS METHOD IS VERY EFFECTIVE, BUT IT USUALLY REQUIRES AN EXPERIENCED VEHICLE OPERATOR AND A GOOD ASSISTANT. THE ASSISTANT MUST OBSERVE THE ALIGNMENT OF THE DRIVE STEEL AND THE VIBRO AND COMMUNICATE WITH THE OPERATOR THE REQUIRED ADJUSTMENTS

A	BF	06/11/13	 <p>MacLean Power Systems, LLC dba <b>FORESIGHT PRODUCTS</b> 6430 EAST 49TH DRIVE COMMERCE CITY, COLORADO 80022</p>	
REV.	BY	DATE		
DIMENSIONS: INCHES [MM]			TITLE: <b>VIBRATORY PLATE COMPACTOR FOR ANCHOR INSTALLATION</b>	
<b>PROPRIETARY AND CONFIDENTIAL</b> THIS DOCUMENT AND THE INFORMATION IT CONTAINS IS THE SOLE PROPERTY OF MACLEAN POWER, LLC dba FORESIGHT PRODUCTS. IT IS NOT TO BE COPIED OR REPRODUCED IN WHOLE OR PART, NOR IS THE INFORMATION TO BE RELAYED TO ANY OTHER INDIVIDUAL COMPANY WITHOUT THE WRITTEN PERMISSION FROM MACLEAN POWER, LLC, dba FORESIGHT PRODUCTS. ACCEPTANCE OF THIS DOCUMENT CONSTITUTES AGREEMENT TO THESE RESTRICTIONS.				
PART NUMBER: I0020-ODA		REV: A	SCALE: 1:128	SHEET NUMBER: 1 OF 1